

"Kalite asla tesadüf değildir"
"Quality is never a coincidence"



**almira lift**[®]
elevator systems



www.almiralift.com.tr



İÇİNDEKİLER
CONTENTS



ÜRETİM - PRODUCTION	02
FİRMA PROFİLİ - COMPANY PROFILE	03
KABİNLER - CABINS	04 - 19
TABANLAR - FLOORS	20
TAVANLAR - CEILINGS	21
KAPLAMALAR - COATINGS	22 - 23
ÇARPMA KAPILAR - MANUAL DOORS	24
KAPI MEKANİZMALARI - DOORS OPERATORS	25
OTOMATİK KAPILAR - AUTOMATIC DOORS	26 - 27
MOTORLAR - MOTORS	28 - 29
KUMANDA PANOLARI - CONTROL PANELS	30 - 35
BUTONLAR - COPS & LOPS	36 - 39
SÜSPANSİYONLAR - SUSPENSIONS	40 - 41
ASANSÖR ÇİZİMLERİ - LIFT DRAWINGS	42 - 44
YEDEK PARÇALAR - SPARE PARTS	45
PLATFORMLAR - PLATFORMS	46
MONŞARJ ASANSÖR - DUMBWAITER ELEVATOR	47

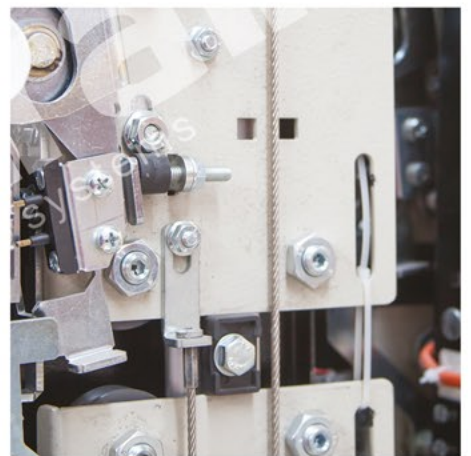
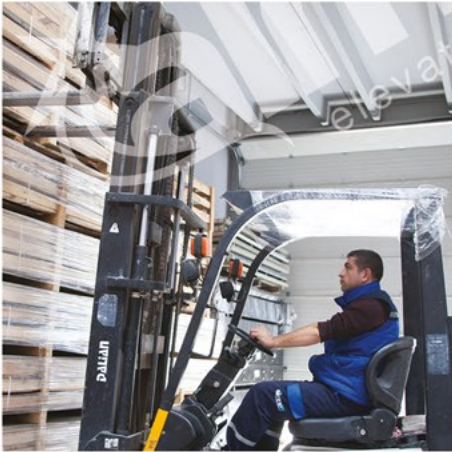
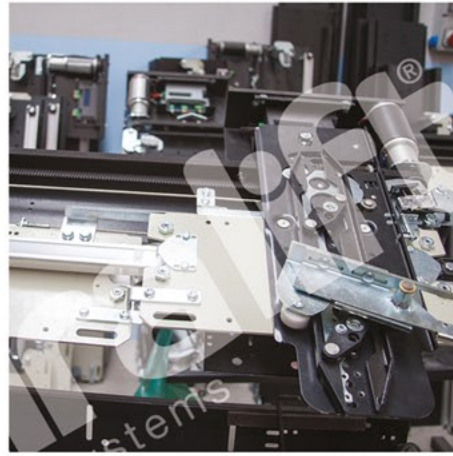



ÜRÜN KODU - PRODUCT CODE

KATRİNA 101



- Kaplama** : Desenli mozaik paslanmaz çelik kaplaması, dikey olarak döşenmekte
- Aksesuar** : Ayna çelik sac
- Ayna** : Dekoratif kesimli 6 mm kalınlıkta, bütün olarak boy aynası
- Taban** : 20 mm doğal granit
- Tavan** : İçeriden açılır, lazer işlemeli ve desenli ayna çelik sac
- Tutma Yeri** : Paslanmaz çelikten küpeşte
- Covering** : Patterned mosaic stainless steel coating, installed vertically
- Accessories** : Mirror steel sheet
- Mirror** : Decorative cut, in 6 mm thickness, full length mirror
- Floor** : 20 mm natural granite
- Ceiling** : Opened from inside, laser engraved and patterned mirror steel sheet
- Handrails** : Stainless steel handrail



T18

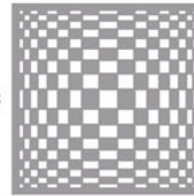

DP100



STAR GALAXY

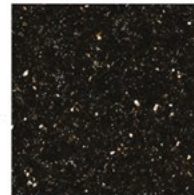

ÜRÜN KODU - PRODUCT CODE

MARMARA 102



T01

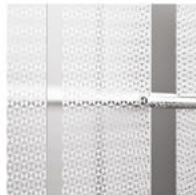

DP118

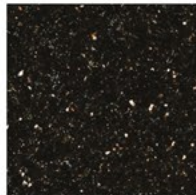

STAR
GALAXY



- Kaplama** : Desenli mozaik paslanmaz çelik kaplaması, dikey olarak döşenmekte
- Aksesuar** : Ayna çelik sac
- Ayna** : Dekoratif kesimli 6 mm kalınlıkta, bütün olarak orta boy ayna
- Taban** : 20 mm doğal granit
- Tavan** : İçeriden açılır, lazer işlemeli ve desenli Ayna çelik sac
- Tutma Yeri** : Paslanmaz çelikten küpeşte

- Covering** : Patterned mosaic stainless steel coating, installed vertically
- Accessories** : Mirror steel sheet
- Mirror** : Decorative cut, in 6 mm thickness, half length mirror
- Floor** : 20 mm natural granite
- Ceiling** : Opened from inside, laser engraved and patterned Mirror steel sheet
- Handrails** : Stainless steel handrail

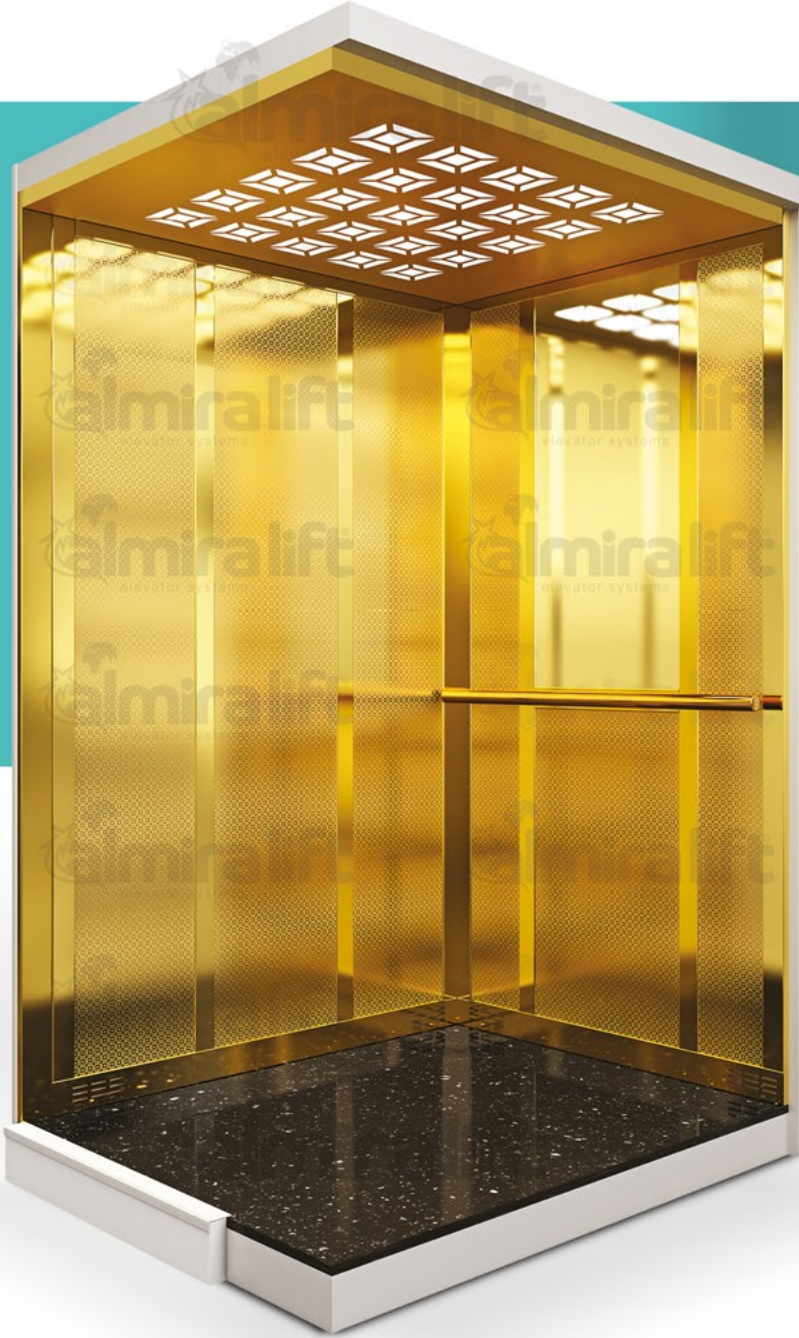

ÜRÜN KODU - PRODUCT CODE

GOLD 103

- Kaplama** : Desenli mozaik paslanmaz çelik kaplaması, dikey olarak döşenmekte
- Aksesuar** : Ayna çelik sac
- Ayna** : Dekoratif kesimli 6 mm kalınlıkta, bütün olarak boy aynası
- Taban** : 20 mm doğal granit
- Tavan** : İçeriden açılır, lazer işlemeli ve desenli ayna çelik sac
- Tutma Yeri** : Paslanmaz çelikten küpeşte
- Covering** : Patterned mosaic stainless steel coating, installed vertically
- Accessories** : Mirror steel sheet
- Mirror** : Decorative cut, in 6 mm thickness, full length mirror
- Floor** : 20 mm natural granite
- Ceiling** : Opened from inside, laser engraved and patterned mirror steel sheet
- Handrails** : Stainless steel handrail



T03



DP117



STAR GALAXY

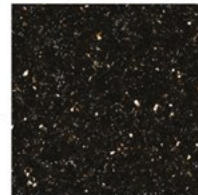

ÜRÜN KODU - PRODUCT CODE

ASYA 104

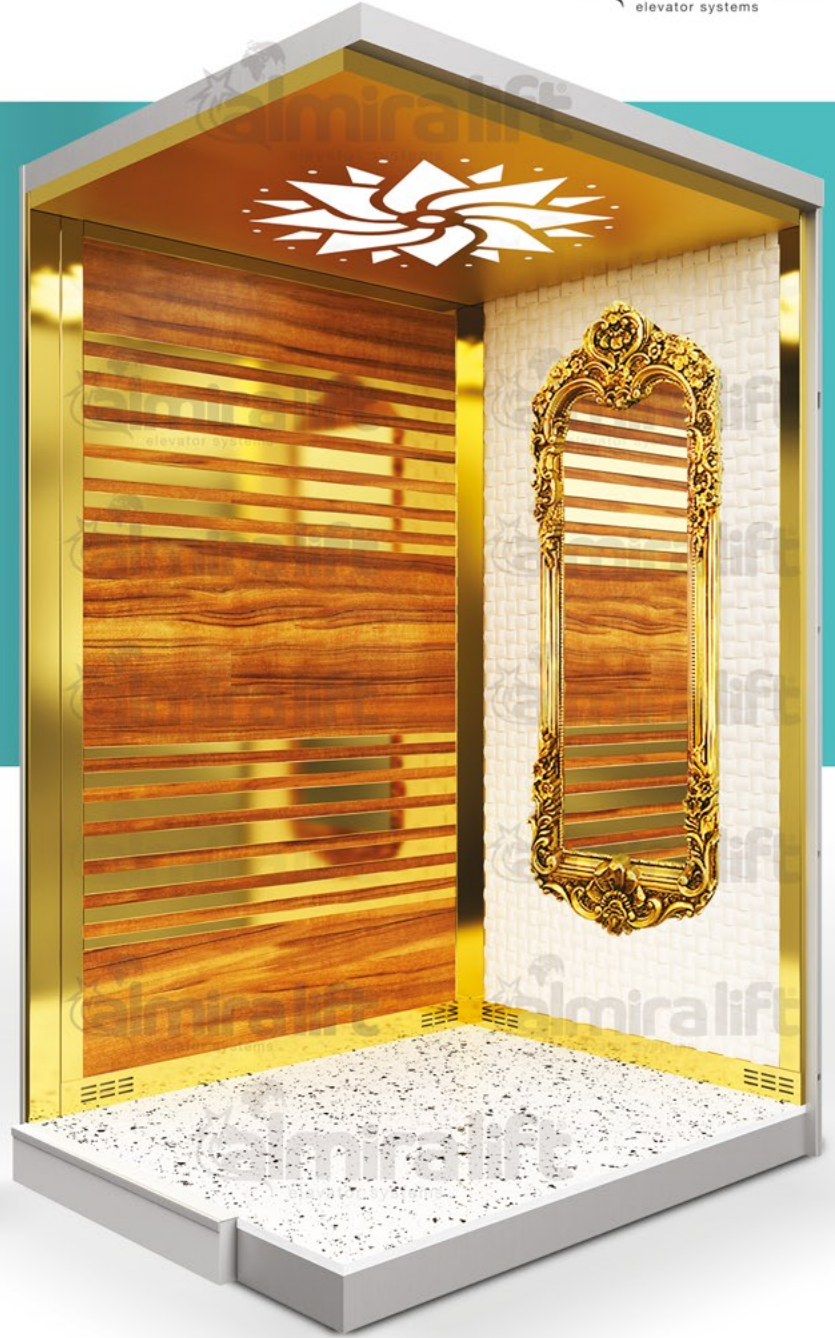

T12



DP101

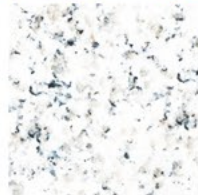

PERLA



Kaplama : Yatay olarak yerleştirilmiş özel altın kaplama elemanı

Aksesuar : Ayna çelik sac

Ayna : Dekoratif kesimli 6 mm kalınlıkta, bütün olarak orta boy ayna

Taban : 20 mm doğal granit

Tavan : İçten açılmalı, ayna paslanmaz, lazer kesim desenli

Tutma Yeri : Paslanmaz çelikten küpeşte

Covering : Vertically installed special gold plate component

Accessories : Mirror steel sheet

Mirror : Decorative cut, in 6 mm thickness, half length mirror

Floor : 20 mm natural granite

Ceiling : Interior opening, mirror st. st., laser cut

Handrails : Stainless steel handrail



ÜRÜN KODU - PRODUCT CODE

ARTOS 105



- Kaplama** : Yatay olarak döşenmiş taş kaplamalı özel paslanmaz çelik
- Aksesuar** : Ayna Paslanmaz
- Ayna** : Dekoratif kesimli 6 mm kalınlıkta, bütün olarak boy aynası
- Taban** : 20 mm doğal granit
- Tavan** : İçten açılmalı, ayna paslanmaz, lazer kesim desenli
- Tutma Yeri** : Paslanmaz çelikten küpeşte
- Covering** : Horizontally installed stone coated special stainless steel
- Accessories** : Mirror Stainless Steel
- Mirror** : Decorative cut, in 6 mm thickness, full length mirror
- Floor** : 20 mm natural granite
- Ceiling** : Interior opening, mirror st. st., laser cut
- Handrails** : Stainless steel handrail



T17



DP100



STAR GALAXY

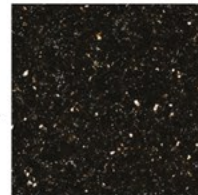

ÜRÜN KODU - PRODUCT CODE

ARAS 106



T17



DP101

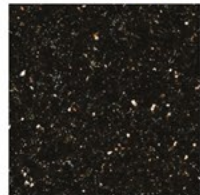

STAR GALAXY



- Kaplama** : Yatay olarak döşenmiş taş kaplamalı özel paslanmaz çelik
- Aksesuar** : Ayna Paslanmaz
- Ayna** : Dekoratif kesimli 6 mm kalınlıkta, bütün olarak boy aynası
- Taban** : 20 mm doğal granit
- Tavan** : İçten açılmalı, ayna paslanmaz, lazer kesim desenli
- Tutma Yeri** : Paslanmaz çelikten küpeşte
- Covering** : Horizontally installed stone coated special stainless steel
- Accessories** : Mirror Stainless Steel
- Mirror** : Decorative cut, in 6 mm thickness, full length mirror
- Floor** : 20 mm natural granite
- Ceiling** : Interior opening, mirror st. st., laser cut
- Handrails** : Stainless steel handrail

ÜRÜN KODU - PRODUCT CODE

AKSU 107

- Kaplama** : Boyalı çelik - RAL
- Aksesuar** : Boyalı çelik sac
- Ayna** : Dekoratif kesimli 6 mm kalınlıkta, bütün olarak boy aynası
- Taban** : 20 mm doğal granit
- Tavan** : İçten açılmalı, ayna paslanmaz, lazer kesim desenli
- Tutma Yeri**: Paslanmaz çelikten küpeşte
- Covering** : Painted Steel - RAL
- Accessories**: Painted steel sheet
- Mirror** : Decorative cut, in 6 mm thickness, full length mirror
- Floor** : 20 mm natural granite
- Ceiling** : Interior opening, mirror st. st., laser cut
- Handrails** : Stainless steel handrail



T13



RAL 7037



TBN C01

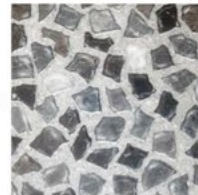

ÜRÜN KODU - PRODUCT CODE

RİVARO 108



T13



RAL 5015

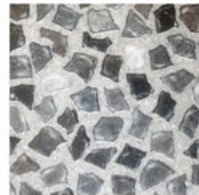

TBN C01



- Kaplama** : Boyalı çelik - RAL
Aksesuar : Boyalı çelik sac
Ayna : Dekoratif kesimli 6 mm kalınlıkta, bütün olarak boy aynası
Taban : 20 mm doğal granit
Tavan : İçten açılmalı, ayna paslanmaz, lazer kesim desenli
Tutma Yeri : Paslanmaz çelikten küpeşte
- Covering** : Painted Steel - RAL
Accessories : Painted steel sheet
Mirror : Decorative cut, in 6 mm thickness, full length mirror
Floor : 20 mm natural granite
Ceiling : Interior opening, mirror st. st., laser cut
Handrails : Stainless steel handrail

ÜRÜN KODU - PRODUCT CODE

RİVA 109

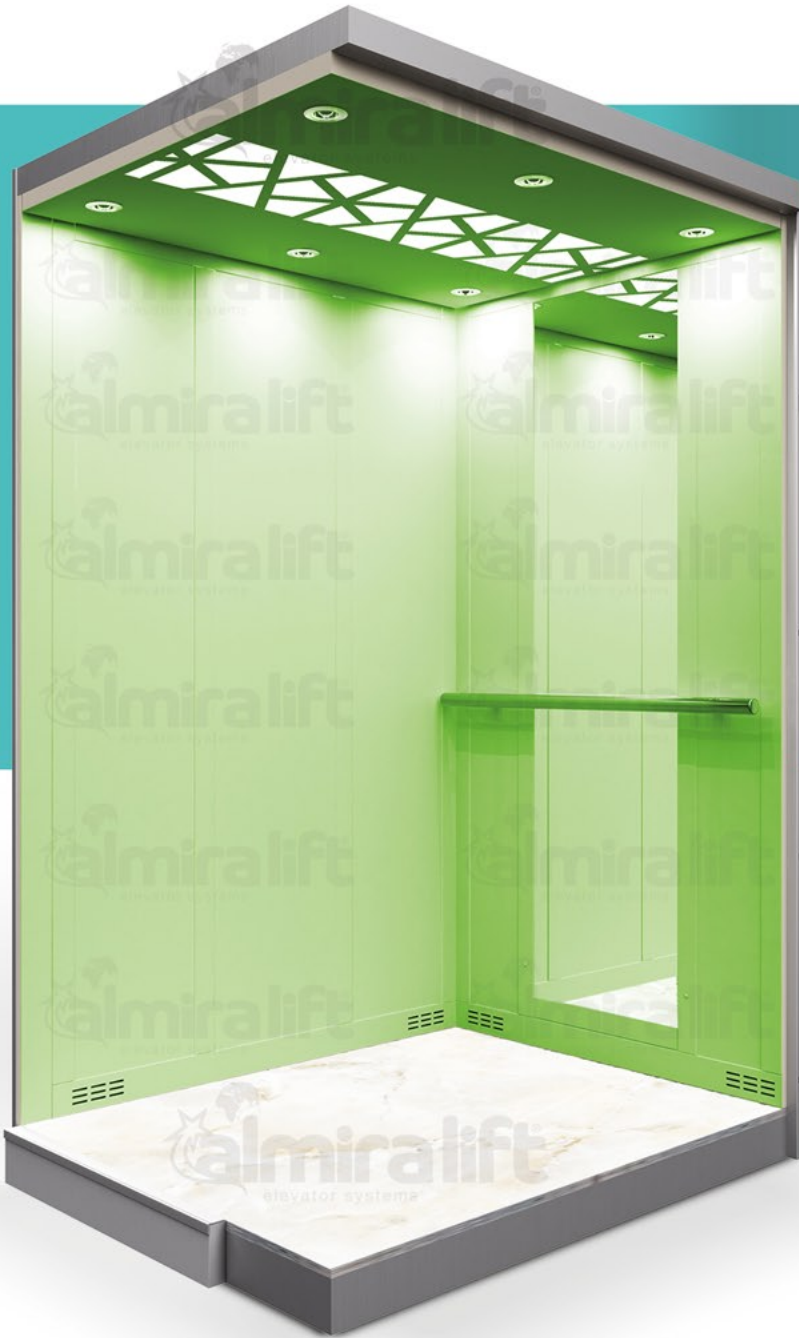

Kaplama	: Boyalı çelik - RAL
Aksesuar	: Boyalı çelik sac
Ayna	: Dekoratif kesimli 6 mm kalınlıkta, bütün olarak boy aynası
Taban	: 20 mm doğal granit
Tavan	: İçten açılmali, ayna paslanmaz, lazer kesim desenli
Tutma Yeri	: Paslanmaz çelikten küpeşte
Covering	: Painted Steel - RAL
Accessories	: Painted steel sheet
Mirror	: Decorative cut, in 6 mm thickness, full length mirror
Floor	: 20 mm natural granite
Ceiling	: Interior opening, mirror st. laser cut
Handrails	: Stainless steel handrail



T13



RAL 6018



TBN C03



ÜRÜN KODU - PRODUCT CODE

FLAMİNGO 110

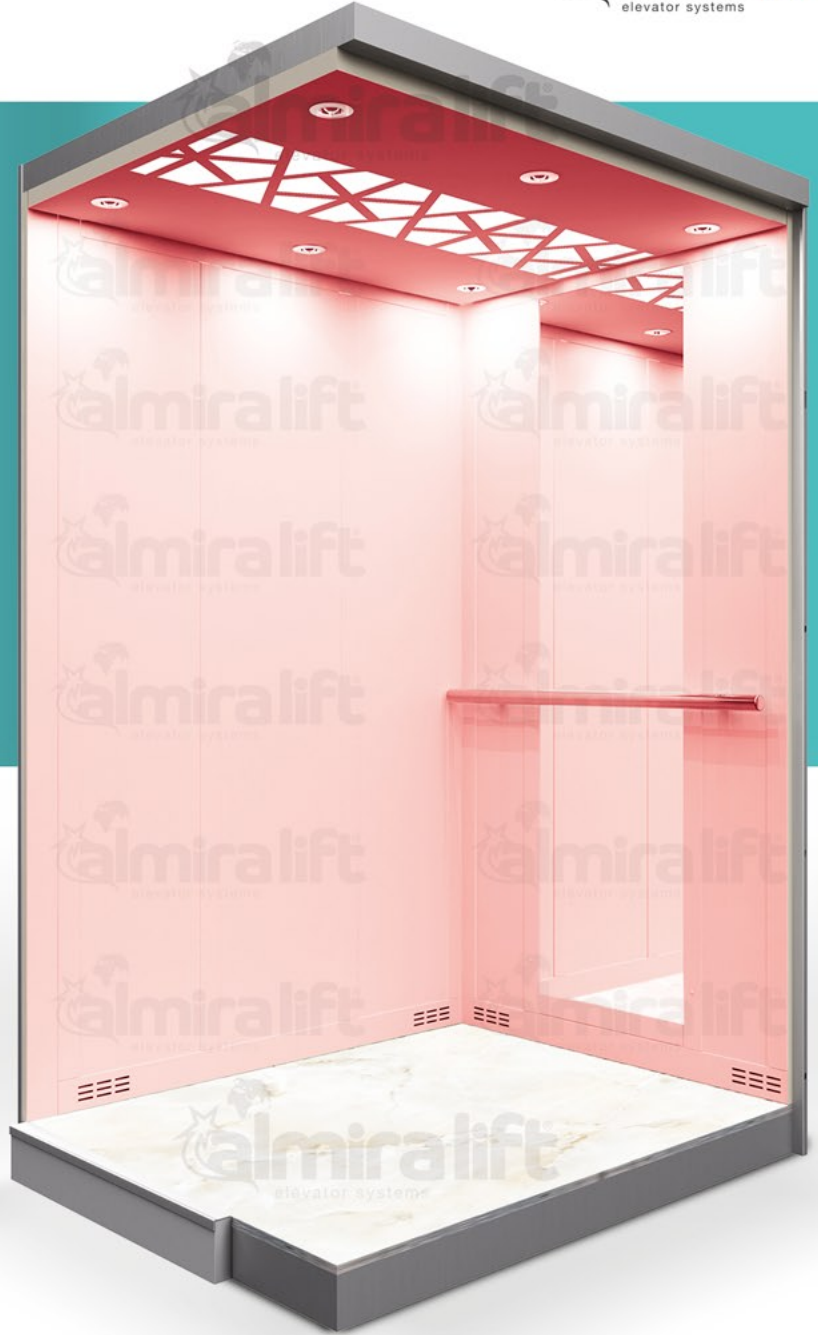

T13



RAL 3014



TBN
C03



Kaplama : Boyalı çelik - RAL

Aksesuar : Boyalı çelik sac

Ayna : Dekoratif kesimli 6 mm kalınlıkta, bütün olarak boy aynası

Taban : 20 mm doğal granit

Tavan : İçten açılmalı, ayna paslanmaz, lazer kesim desenli

Tutma Yeri : Paslanmaz çelikten küpeşte

Covering : Painted Steel - RAL

Accessories : Painted steel sheet

Mirror : Decorative cut, in 6 mm thickness, full length mirror

Floor : 20 mm natural granite

Ceiling : Interior opening, mirror st. laser cut

Handrails : Stainless steel handrail



ÜRÜN KODU - PRODUCT CODE

AKSU 111

Kaplama	: Dekoratif süsleme
Aksesuar	: Ayna çelik sac
Ayna	: Tam boy ayna
Taban	: 20 mm doğal granit
Tavan	: İçten açılmalı, ayna paslanmaz, lazer kesim desenli
Tutma Yeri	: Paslanmaz çelikten küpeşte
Covering	: Decorative ornamentation
Accessories	: Mirror Stainless Steel
Mirror	: Full length mirror
Floor	: 20 mm natural granite
Ceiling	: Interior opening, mirror st. st., laser cut
Handrails	: Stainless steel handrail



T01

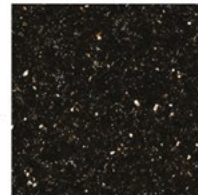

C110

STAR
GALAXY

ÜRÜN KODU - PRODUCT CODE

AKSU 112



T01



C14

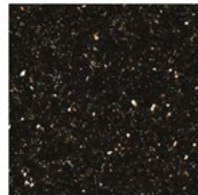

STAR
GALAXY



- Kaplama** : Dekoratif süsleme
- Aksesuar** : Ayna çelik sac
- Ayna** : Tam boy ayna
- Taban** : 20 mm doğal granit
- Tavan** : İçten açılmalı, ayna paslanmaz, lazer kesim desenli
- Tutma Yeri** : Paslanmaz çelikten küpeşte

- Covering** : Decorative ornamentation
- Accessories** : Mirror Stainless Steel
- Mirror** : Full length mirror
- Floor** : 20 mm natural granite
- Ceiling** : Interior opening, mirror st. st., laser cut
- Handrails** : Stainless steel handrail

ÜRÜN KODU - PRODUCT CODE

ALARA 113

- Kaplama** : Boyalı çelik. RAL.
- Aksesuar** : Ayna Paslanmaz
- Ayna** : Orta tam boy, 6 mm bizoteli ayna
- Taban** : 20 mm doğal granit
- Tavan** : İçten açılmalı, ayna paslanmaz, lazer kesim desenli
- Tutma Yeri** : İkili paslanmaz küpeşte
- Covering** : Painted steel. RAL.
- Accessories** : Mirror stainless steel
- Mirror** : Half length mirror
6 mm beveled mirror
- Floor** : 20 mm natural granite
- Ceiling** : Interior opening, mirror st.
st., laser cut
- Handrails** : Double stainless steel handrail



T05

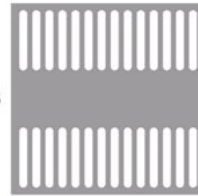

RAL 7032



STAINLESS STEEL

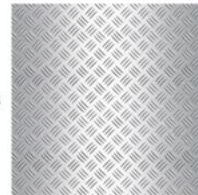

ÜRÜN KODU - PRODUCT CODE

TOROS 114



T15



DP100



TBN
C03



Kaplama	: Panoramik
Aksesuar	: Ayna Paslanmaz
Ayna	: Orta tam boy, 6 mm bizoteli ayna
Taban	: 20 mm doğal granit
Tavan	: İçten açılmalı, ayna paslanmaz, lazer kesim desenli
Tutma Yeri	: İkili paslanmaz küpeşte

Covering	: Panoramic
Accessories	: Mirror stainless steel
Mirror	: Half length mirror 6 mm beveled mirror
Floor	: 20 mm natural granite
Ceiling	: Interior opening, mirror st. st., laser cut
Handrails	: Double stainless steel handrail



ÜRÜN KODU - PRODUCT CODE

TERKOS 115



Kaplama	: Mantar Panoramik
Aksesuar	: Ayna Paslanmaz
Ayna	: Orta tam boy, 6 mm bizoteli ayna
Taban	: 20 mm doğal granit
Tavan	: İçten açılmalı, ayna paslanmaz, lazer kesim desenli
Tutma Yeri	: İkili paslanmaz küpeşte
Covering	: Mushroom Panoramic
Accessories	: Full length mirror
Mirror	: Half length 6 mm beveled mirror
Floor	: 20 mm natural granite
Ceiling	: Interior opening, mirror st. st, laser cut
Handrails	: Double stainless steel handrail



T13



DP100



MINHO



ÜRÜN KODU - PRODUCT CODE

TUNA 116



T05



DP101



TBN
C03



Kaplama : Sarı Mantar Panoramik

Aksesuar : Ayna Paslanmaz

Ayna : Orta tam boy, 6 mm bizoteli ayna

Taban : 20 mm doğal granit

Tavan : İçten açılmalı, ayna paslanmaz, lazer kesim desenli

Tutma Yeri : İkili paslanmaz küpeşte

Covering : Gold Panoramic

Accessories : Full length mirror

Mirror : Half length 6 mm beveled mirror

Floor : 20 mm natural granite

Ceiling : Interior opening, mirror st. st., laser cut

Handrails : Double stainless steel handrail

**GOLDEN****SOFİTA****MULTICOLOR RED****MİNHO****PERLA****YERLİ KOYU****ROSA PORİNO****STAR GALAXY****FÜME****PVC 3717****PVC ES - 5****TBN C01****TBN C02****TBN C03****TBN C04****TBN C05****TBN C06****TBN C07**

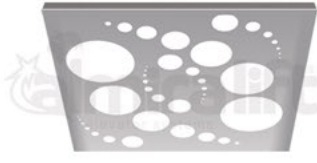

T01



T02

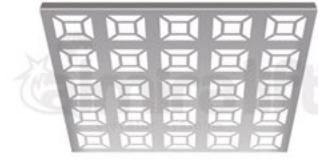

T03



T04



T05



T06



T07



T08

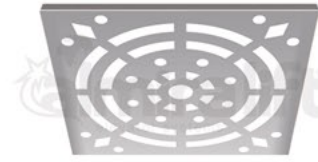

T09



T10



T11



T12



T13



T14



T15



T16



T17

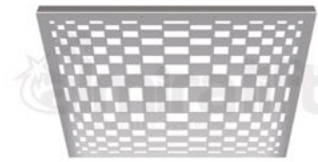

T18

RAL BOYA KODLARI
RAL PAINT CODES

RAL 2004



RAL 3020



RAL 3014



RAL 3003



RAL 5010



RAL 5015



RAL 6018



RAL 7037



RAL 7032



RAL 5018

PASLANMAZLAR
STAINLESS STEELS

DP100



DP101



DP102



DP103



DP104



DP105



DP106



DP107



DP108



DP109



DP110



DP111



DP112



DP113



DP114



DP115



DP116



DP117



DP118



DP119



DP120



DP121

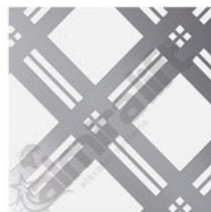

DP122



DP123



DP124

CAM GÖRSELLER
GLASS IMAGES



C100



C101



C102



C103



C104

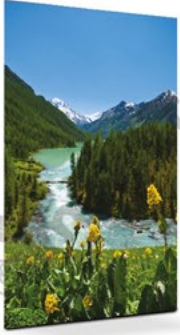

C105



C106



C107



C108



C109



C110



C111



C112



C113



C114

LAMİNATLAR
LAMINATES



L100



L101



L102



L103



L104



L105



K100



K101



K102



K103



K104



**2 Panel Teleskopik
Kat Mekanizması**

2 Panels Telescopic Landing
Door Operator

**2 Panel Merkezi
Kat Mekanizması**
2 Panels Central Landing
Door Operator

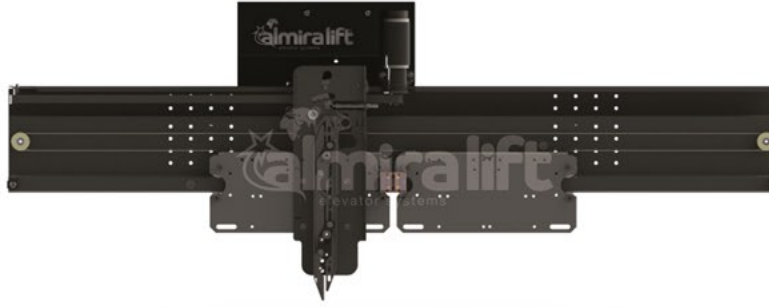

2 Panel Merkezi Kabin Operatörü
2 Panels Central Cabin Operator

2 Panel Teleskopik Kabin Operatörü
2 Panels Telescopic Cabin Operator





2 Panel Sol
2 Panels Left



2 Panel Sağ
2 Panels Right

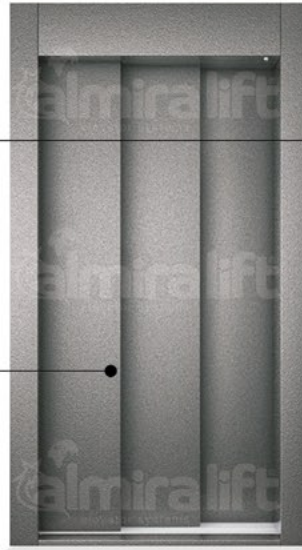

3 Panel Sol
3 Panels Left



3 Panel Sağ
3 Panels Right



2 Panel Merkezi
2 Panels Central



4 Panel Merkezi
4 Panels Central



6 Panel Merkezi
6 Panels Central



Çerçeveseli Cam Panel
Framed Glass Panel



Çerçeveseli Cam Panel
Framed Glass Panel



Komple Cam Panel
Complete Glass Panel



AKIŞ

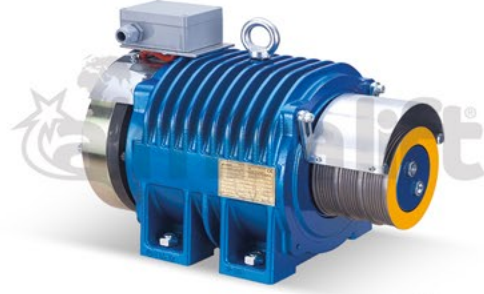

AKAR



AKIŞ



AKAR



EKER



A.SASSI

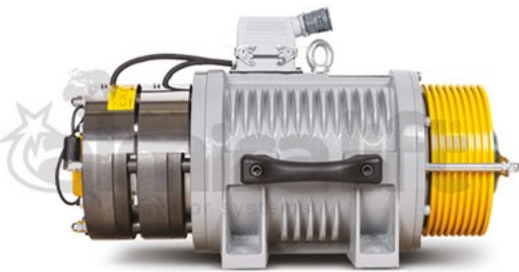

EKER



A.SASSI

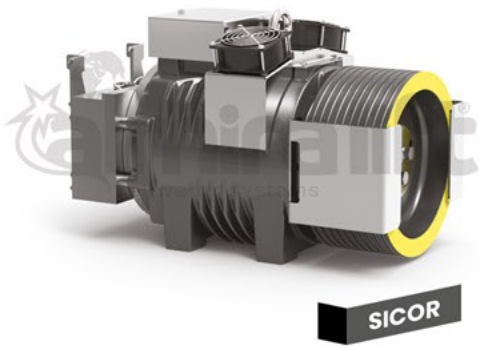

ARCODE



**MRL Dişlisiz Sistemler için
Kontrol Cihazı Makine Dairesi**
Controller For MRL (Gearless)
Systems Machine Room



Seri Bağlantılı Revizyon Kutusu
Revision Box With Serial Connection



**Acil Kurtarma Makinesi ile
VVVF Kontrol Cihazı**
VVVF Controller With Emergency
Rescue Machine

ARCODE ÖZELLİKLER**Motor Kontrolü:**

Senkron (dişlisiz) Makine Asenkron (dişli) Makine

Tahrik Tipi

Makine Daireli Makine Dairesiz (MRL)

Asansör Hızı (Maksimum)

4 m/s

Grup Çalışabilme Özelliği

8 Asansöre Kadar

Durak Sayısı

64 Durak

Seri Haberleşme

Hazır Tesisatlı CANbus Seri Haberleşmesi ile (standart)

Otomatik Kata Getirme

1-Faz 220VAC UPS Akü Grubu Bağlantısı

Enkoder

Artımsal Enkoder (5V TTL veya 10-30V HTL)
Mutlak Enkoder (EnDat, SSI, SinCos veya BISS)

Kat Tesisatı

- Hazır tesisatlı CANbus seri haberleşmesi ile
- Paralel tesisat ile (opsiyonel paralel tesisat kartı ile 16 durağa kadar)

Kalkışta Geri Kaymayı Önleme

- Ön-tork fonksiyonu (yük hücresinden alınan analog yük bilgisi ile)
- Kalkışta tutma fonksiyonu (harici yük hücresi gerektirmeden)

El Terminali Desteği**AREM**

- Kullanıcı dostu ve çok lisanlı renkli TFT ekran
- CANbus üzerindeki herhangi bir noktadan sistemi kontrol edebilme

Yazılım Güncelleme

AREM ile tüm birimlerin tek seferde hızlı ve güvenilir güncellenebilmesi

ARCODE FONKSİYONLAR

- Artımsal veya mutlak değer motor enkoderi ile kabin pozisyon bilgisi
- 2 kapı desteği ile duraklara göre bağımsız otomatik kapı kontrolü
- Motor tanıma / Kuyu Tanıma / Kontrol kazançlarını öğrenme yetenekleri sayesinde otomatik ayar yapma
- Direkt duruş sayesinde kusursuz konfor
- Dahili EMI filtre
- Dahili DC şok
- Şebeke ve acil besleme arasında geçiş için dahili röleler
- Kapı ön açma ve hızlı kalkış (opsiyonel kapı köprüleme modülü ile)
- Dijital kuyu öğrenme / Ek ayar ve donanım gerektirmeyen kısa kat seyahati
- Hassas duruş özelliği
- 48 -230VAC güvenlik devresi gerilimi
- Enerji tasarruf modu
- Programlanabilir giriş-çıkışlar
- Asansör test menüsü

ARCODE PROPERTIES**Motor Control:**

Synchronous (gearless) Machine Asynchronous (geared) Machine

Drive Type:

Machine Room (MR) Machine Roomless (MRL)

Elevator Speed (Maximum)

4 m/s

Group working feature

Up to 8 Elevators

Stop Number

64 Stops

Serial Communication

Including Pre-wired (Factory preparation) CANbus Serial Communication (Standard)

Automatically Driving To Floor

1-phase 220VAC UPS Battery Group Connection

Encoder

Incremental Encoder (5V TTL or 10-30V HTL)
Absolute Encoder (EnDat, SSI, SinCos or BISS)

Landing Facilities

- Including Pre-wired (Factory preparation) CANbus serial Communication
- With parallel Installation (With optional parallel installation card up to 16 stops)

Preventing Backward Slipping When Starting

- Pre-torque fonction (with analogue loading data obtained from loading cell)
- Hold up while starting function (without any required external loading cell)

Hand Mobile Terminal**AREM**

- User-friendly and multi langual colored TFT display
- The ability to control the system from any place using CANbus

Software Update

The ability to update all unites fastly and safely in a sitting using AREM Device

ARCODE FUNCTIONS

- Car position information with incremental or absolute value motor encoder
- Independent automatic door control according to stops with 2 door support
- Automatic adjustment thanks to the ability to motor learning / shaft learning / Control gains learning
- Perfect comfort thanks to direct standing
- Internal EMI filter
- Internal DC shock
- Internal relays for switching between network and emergency supply
- Door pre-opening and rapid starting (with optional door bridging module)
- Digital shaft learning / Short floor traveling that does not require additional adjustment and equipment
- Including sensitive standing feature
- 48 -230VAC safety circuit voltage
- Energy saving mode
- Programmable inputs-outputs
- Elevator test menu

ADRIVE



**MRL Dişlisiz Sistemler için
Kontrol Cihazı Makine Dairesi**
Controller For MRL (Gearless)
Systems Machine Room



Seri Bağlantılı Revizyon Kutusu
Revision Box With Serial Connection



**Acil Kurtarma Makinesi ile
VVVF Kontrol Cihazı**
VVVF Controller With Emergency
Rescue Machine

ADRIVE ÖZELLİKLER

Güç Devresi

60-120V gerilimli akü grubu 220VAC çıkışlı uygun güçte bir UPS ile beslenebilme

Kontrol Devresi

Harici 24Vdc besleme ile canlı kalabilme

Aşırı Hız Uyarısı

0,63 m/s 'den yüksek hızlarda

Hata Kaydı

Son 256 hatanın hafızada tutulmasıyla geçmişe dönük arıza takip imkanı

Menü Dilleri

Türkçe, İngilizce, Fransızca, Macarca dil seçenekleri

Standartlara Uygunluk

EMC testi sertifikalı

ADRIVE PROPERTIES

Power Circuit

60-120V battery pack can be fed with a 220VAC UPS in suitable power

Control Circuit

Being active with external 24Vdc supply

Overload Alarm

At speeds higher than 0.63 m / s

Error Record

Possibility of retrospective fault tracking by keeping the last 256 errors in the memory

Menu Languages

Turkish, English, French, Hungarian languages options

Compliance with Standards

Certified in EMC test

ADRIVE FONKSİYONLAR

- Yerli tasarım, yerli üretim ve tam teknik servis desteği.
- Asenkron (kapalı veya açık çevrim) ve Senkron (dişlisiz) motorlara uyumluluk.
- Yüksek seyahat konforu ve katlarda yükten bağımsız olarak hassas duruş.
- Vektör kontrolü sayesinde güçlü kalkış ve sürme momenti.
- Asansörün elektrik sarfiyatında %40'a varan tasarruf.
- Özellikle jeneratör bulunan asansörlerde motor akımının kontrol altında tutulmasıyla, şebekeye ani yüklenmelerin engellenmesi.
- Asansörlere özel tasarım ve asansör uygulamalarına özel parametreler (metre, m/s gibi uygun birimler ile).
- 10 Khz IPM anahtarlama frekansı ile en aza indirgenmiş motor sürme sesi.
- Dahili DC REAKTÖR sayesinde çevre dostu enerji sarfiyatı.
- 4 adet düşük ses seviyeli fan ile etkin ve sessiz soğutma.
- Tamamı elektriksel yalıtımlı kontrol giriş ve çıkışlar.
- Aşırı yüklenme, yüksek gerilim, düşük gerilim, kısa devre, düşük motor akımı, dengesiz motor akımı, anlık güç kesintisi, faz kaçağı, soğutucu aşırı ısınması, topraklama hatası, aşırı tork, kontak hatası kontrolü ve diğer temel koruma fonksiyonları.
- EMC testi sertifikalı.
- 5,5, 7,5, 11, 15 ve 22 kW güç seçenekleri.

ADRIVE FUNCTIONS

- Domestic design, domestic production and full technical service support.
- Compatibility with Asynchronous and Synchronous (gearless) motors.
- High traveling comfort and precise standing on floors regardless of the load
- Strong starting and driving moment thanks to vector control.
- Up to 40% savings in the electricity consumption of the elevator.
- Preventing sudden loads on the network by keeping the motor current under control, especially in elevators with generators.
- Special design for elevators and special parameters for elevator applications (in suitable units such as meter, m / s)
- Minimized motor driving noise with 10 Khz IPM switching frequency.
- Environmental-friendly consumption thanks to the internal DC REACTOR
- Effective and silent cooling with 4 low noise fans.
- Fully electrically isolated control inputs and outputs.
- Overload, high voltage, low voltage, short circuit, low motor current, unbalanced motor current, instantaneous power failure, phase leakage, cooler overheating, earthing error, overload, contact error control and other basic protection functions
- EMC test certified
- 5,5, 7,5, 11, 15 ve 22 kW power options

ARCUBE



ARCUBE ÖZELLİKLER

Durak Sayısı

16

Tahrik Tipi

Elektrikli

Tesisat

Kabin ve kat butonyerleri ile seri veya paralel bağlantı imkanı ve Arcode uyumlu seri tesisat birimleri

Kabin Pozisyon Bilgisi

Manyetik Şalter ya da motor enkoderi

Kapı Köprüleme

Mevcut

Modeller

4kW (10A) - 5.5kW (14A) - 7.5kW (17A) - 11kW (26A)

Kumanda Tipi

Tek Buton Toplama, Çift Buton Toplama

Grup Kumanda

Dubleks

Asansör Hızı

1.75 m/s

Motor Sürme Tipi

STO fonksiyonlu kontaktörsüz sürüş

Standartlara Uygunluk

EN 81-20

Kalkış Tutma

Ön-tork ve kalkış tutma fonksiyonları ile kalkışta geri kaymayı önleme

ARCUBE FONKSİYONLAR

- VVVF sürücü, kontrol kartı, kurtarma fonksiyonu ve diğer elektrik şalt malzemeleri tek bir monoblok ünitelerde
- STO fonksiyonlu kontaktörsüz tasarım
- Hafif, küçük boyut ve kolay kurulum özelliği
- EN 81-20 standartına uyumlu
- Azaltılmış seyahat kablosu ile düşük maliyet
- Direkt duruş özelliği
- Senkron ve asenkron makineler ile çalışabilme özelliği
- Açık ve kapalı çevrim çalışma özelliği
- Dayanıklı ve uzun ömürlü
- Enerji Tasarrufu

ARCUBE PROPERTIES

Stops Number

16

Drive Type

Electrical

Installation

Serial or parallel connection with Cabin and Landing buttons and Arcode-compatible serial installation units

Cabin Position Information

Cabin Position Information

Door Bridging

Available

Models

4kW (10A) - 5.5kW (14A) - 7.5kW (17A) - 11kW (26A)

Control Type

Single Button Collection, Double Button Collection

Group Control

Duplex

Elevator Speed

1.75 m/s

Motor Driving Type

Contactorless driving with STO function

Compliance with Standards

EN 81-20

Starting Hold

Preventing backwards sliding using pre-torque and starting hold functions

ARCUBE FUNCTIONS

- VVVF drive, control card, rescue function and other electrical switchgears in one monoblock unit
- Contactorless design with STO function
- Light in weight, small size and with easy installation feature
- Compatible with EN 81-20 standard
- Low cost thanks to reduced travel cable
- Direct standing feature
- The ability to work with synchronous and asynchronous machines
- The ability to work with close and open encoder
- Durable and hardwearing
- Energy saving

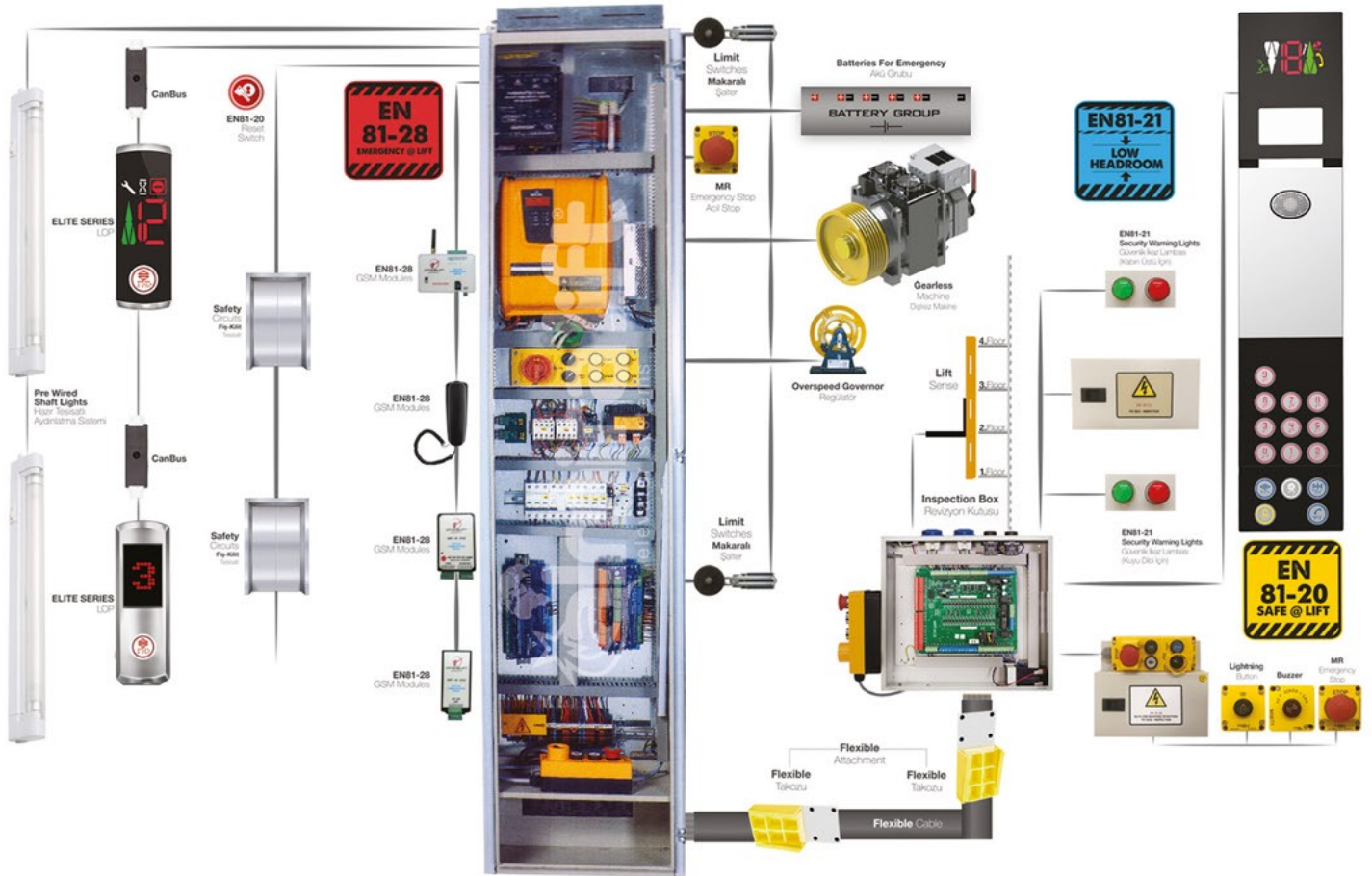



U21TM0006



U21TM0002



U27TM0001



U29TM0001



U21YR0002



U21YR0005



U21TM0004



U21TM0003



U21YR0003



U21YT0001



U20DB0002



U20SM0010



U20SM0001



U28SM0001



U30DJ0002



U20SM0018



U26SM0001



U20SM0001



U20SM0001



U20SM0005



MONŞARJ



U20DJ0003



U20KU0001



U30KU0001



U20KU0002



U20KU0004



U20KU0003

MONTAJ DETAYI
FIXATION DETAILS



ACİL ARAMA KURTARMA SİSTEMİ
URGENT SEARCH AND RESCUE SYSTEM

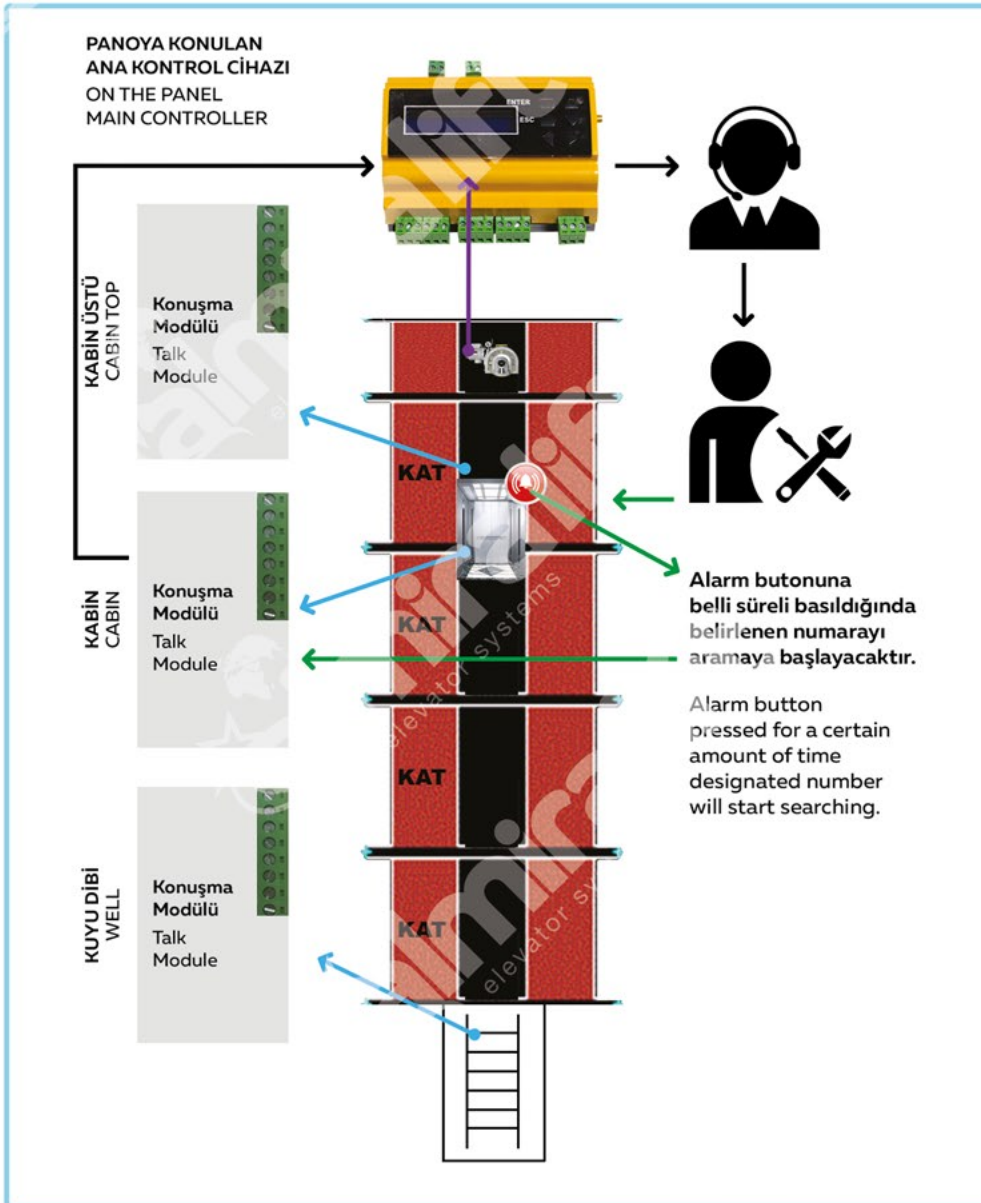

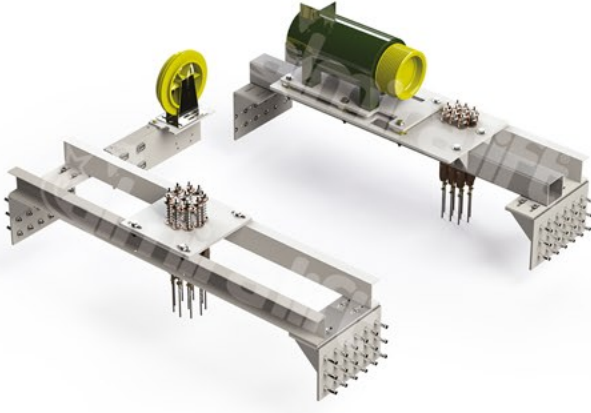

DIŞLİSİZ MAKİNA ŞASESİ
GEARLESS MOTOR STAND



DIŞLİLİ MAKİNA ŞASESİ
GEARBOX MOTOR STAND



MRL KUYU YERLEŞİMİ
MRL SHAFT LAYOUT

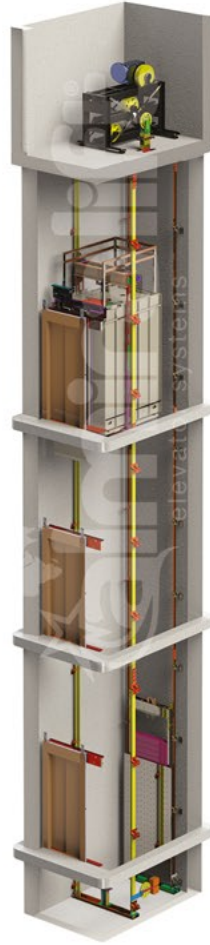

MR KUYU YERLEŞİMİ
MR SHAFT LAYOUT



MRL KUYU YERLEŞİMİ
MRL SHAFT LAYOUT



AĞIRLIK ŞASE 2:1
COUNTERWEIGHT FRAME 2:1



AĞIRLIK ŞASESİ 1:1 ASKI
COUNTERWEIGHT FRAME 1:1



MRL KABİN SÜSPANSİYON 2:1 ASKI
MRL CAR CASE 2:1 PULLEY



L KARKAS 1:1 ASKI
L FRAME 1:1 PULLEY



MR KABİN SÜSPANSİYON 1:1 ASKI
MR CAR CASE 1:1 PULLEY

YOLCU ASANSÖRÜ PASSENGER ELEVATOR

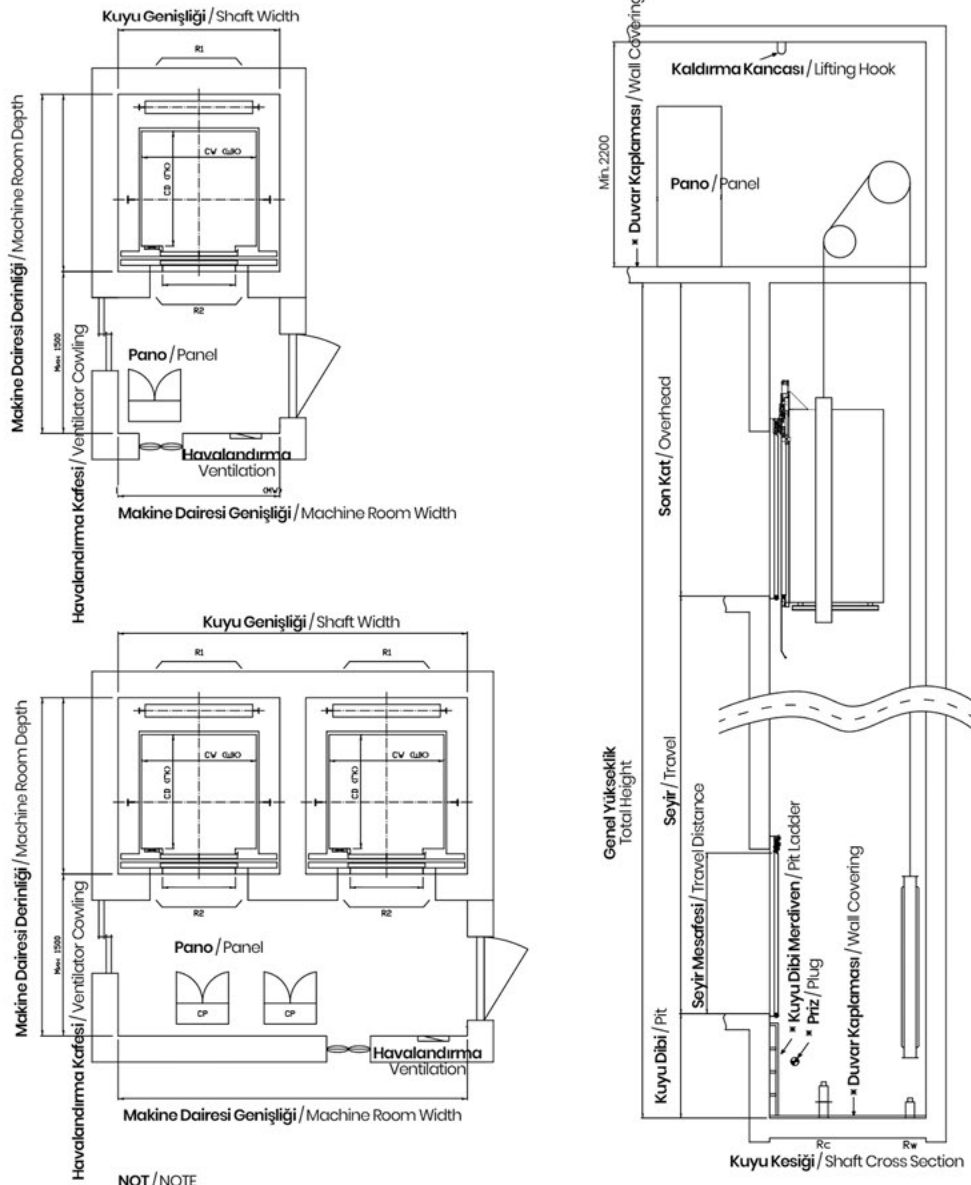

MAKİNE DAİRELİ YOLCU ASANSÖRÜ / PASSENGER ELEVATORS WITH MACHINE ROOM

Hız Speed (M/C)	Kapasite Capacity		Açık Genişlik Opening Width		Kabin Cabin		Kuyu Ölçüsü / Shaft Dimensions				Makine Dairesi / Machine Room				Süsp. Basıncı Susp. Pressure		Kuyu D. Basıncı Pit Pressure		
	kg Paxson	KG	Tip Type	Genişlik Width	CW	CD	HW	HD	HW	HD	MW	MD	MW	MD	R1	R2	RC	RW	
0.40 - 2.0	5	400	2P-CO	700	1100	1000	1550	1650	3250	1600	1850	3100	3550	3100	3700	2300	5150	3200	
	6	450	2P-CO	700	1100	1100	1550	1700	3250	1700	1850	3200	3550	3200	3800	2350	5500	3300	
				800	1400	850	1800	1450	3750	1450	2100	2950	4050	2950					
	7	525	2P-CO	800	1400	950	1800	1550	3750	1550	2100	3050	4050	3050	4200	2800	6200	4500	
	8	630	2P-CO	800	1400	1100	1800	1700	3750	1700	2100	3200	4050	3150	4500	3100	6550	4700	
	9	675	2P-CO	800	1400	1200	1800	1800	3750	1800	2100	3300	4050	3300	4900	3400	7300	5150	
	10	750	2P-CO	800	1400	1300	1800	1900	3750	1900	2100	3400	4050	3400	5400	3850	7800	5500	
	11	900	2P-CO	900	1600	1300	2000	1900	4150	1900	2300	3400	4450	3400	5700	4100	9400	6650	
	13	1000	2P-CO	1000	1600	1400	2150	2000	4450	2000	2450	3500	4750	3500	6150	4600	9950	6900	
				1200	2100	1100	2550	1750	5250	1750	2850	3250	5550	3250					
	0.40 - 2.0	15	1150	2P-CO	1000	1800	1450	2250	2050	4650	2050	2550	3550	4950	3550	9400	7750	12300	8750
					1100	2000	1400	2550	2100	5250	2100	2850	3600	5550	3600	10000	8250	13600	9500
		21	1600	2P-CO	1200	2100	1600	2650	2300	5450	2300	2950	3800	5750	3800	11600	8700	15400	11600
24		1800	2P-CO	1200	2350	1600	2900	2300	5950	2300	3200	3800	6250	3800	13000	9700	17300	13100	
26		2000	2P-CO	1200	2350	1700	2900	2400	5950	2400	3200	3900	6250	3900	14400	10600	19100	14600	
33		2500	2P-CO	1200	2900	2000	2900	2700	5950	2700	3200	4200	6250	4200	17900	12600	23700	18300	

Kapasite (KG) Capacity	Hız Speed	Son Kat Overhead	Kuyu Dibi Pit	Makine Dairesi Yük. Machine Room Height	Not Note
400 - 1600	1.0	3800	1500/(1200)	2200	
	1.6	3900	1600	2400	
	2.0	4000	1700	2400	
400 - 1600	0.40	3900	1600	2500	
	0.63	4000	1700	2500	

HASTANE ASANSÖRÜ HOSPITAL ELEVATOR

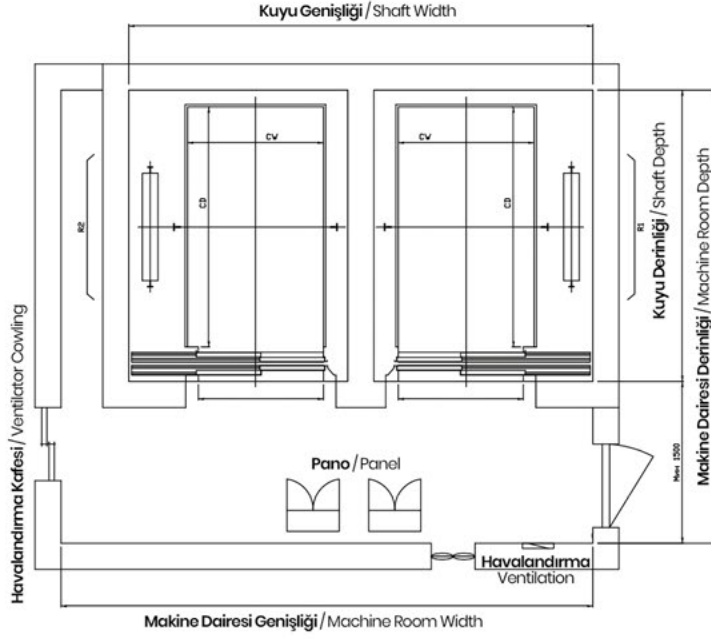
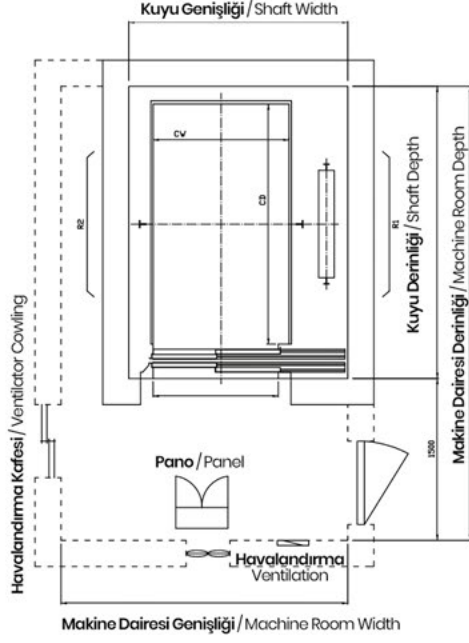

NOT / NOTE

Başkaları tarafından yapılmaktadır
It must be done by others

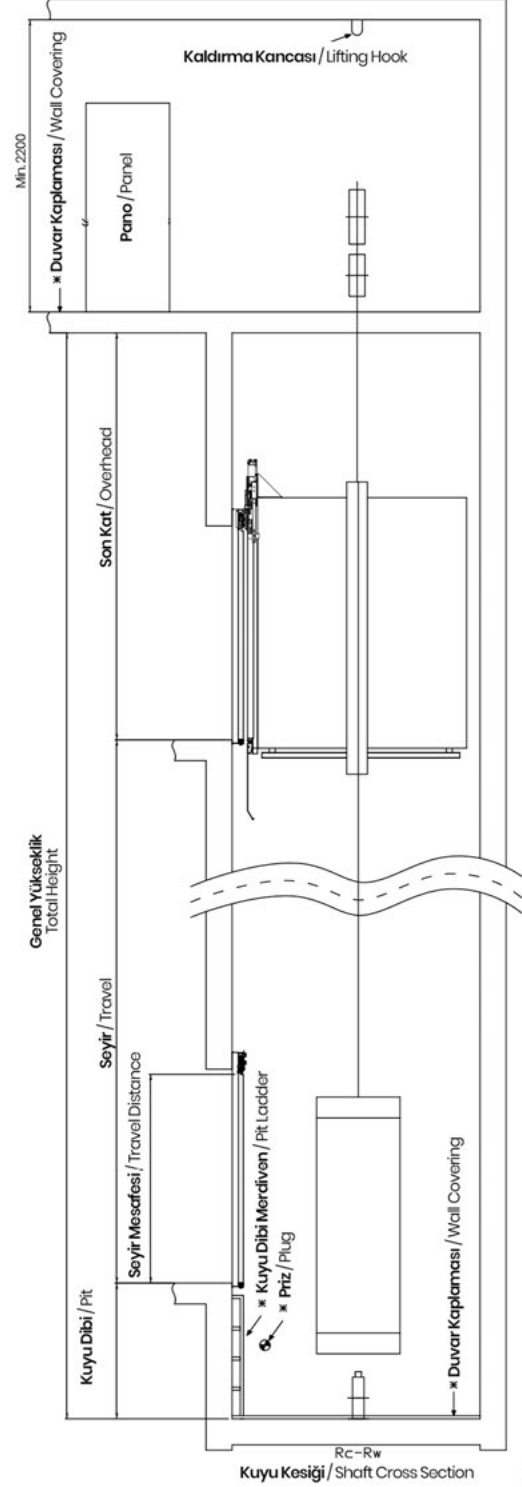

HASTANE ASANSÖRÜ (STANDART ÖLÇÜ) / HOSPITAL ELEVATOR (STANDARD)

Hız Speed (M/C)	Kapasite Capacity Kişi Person KG	Açık Genişlik Opening Width		Kabin Cabin		Kuyu Ölçüsü / Shaft Dimensions				Makine Dairesi / Machine Room				Süsp. Basıncı Susp. Pressure		Kuyu D. Basıncı Pit Pressure		
		Tip Type	Genişlik Width	CW	CD	HW	HD	HW	HD	MW	MD	MW	MD	R1	R2	RC	RW	
0.40	18	1350	2P-2S	1100	1300	2300	2150	2800	4450	2800	2450	4300	4750	4300	7900	6100	8800	6700
2.0	21	1600	2P-2S	1200	1500	2300	2350	2800	4850	2800	2650	4300	5150	4300	11550	8500	9500	7700

HASTANE ASANSÖRÜ (ÖZEL ÖLÇÜ) / HOSPITAL ELEVATOR (NON-STANDARD)

Hız Speed (M/C)	Kapasite Capacity Kişi Person KG	Açık Genişlik Opening Width		Kabin Cabin		Kuyu Ölçüsü / Shaft Dimensions				Makine Dairesi / Machine Room				Süsp. Basıncı Susp. Pressure		Kuyu D. Basıncı Pit Pressure		
		Tip Type	Genişlik Width	CW	CD	HW	HD	HW	HD	MW	MD	MW	MD	R1	R2	RC	RW	
0.40	10	750	2P-2S	1100	1300	2300	2150	2800	4450	2800	2450	4300	4750	4300	6500	4100	8500	6500
2.0	13	1000	2P-2S	1200	1500	2300	2350	2800	4850	2800	2650	4300	5150	4300	6800	5100	9000	7000

PROJE TASARIMI - PROJEC DESING

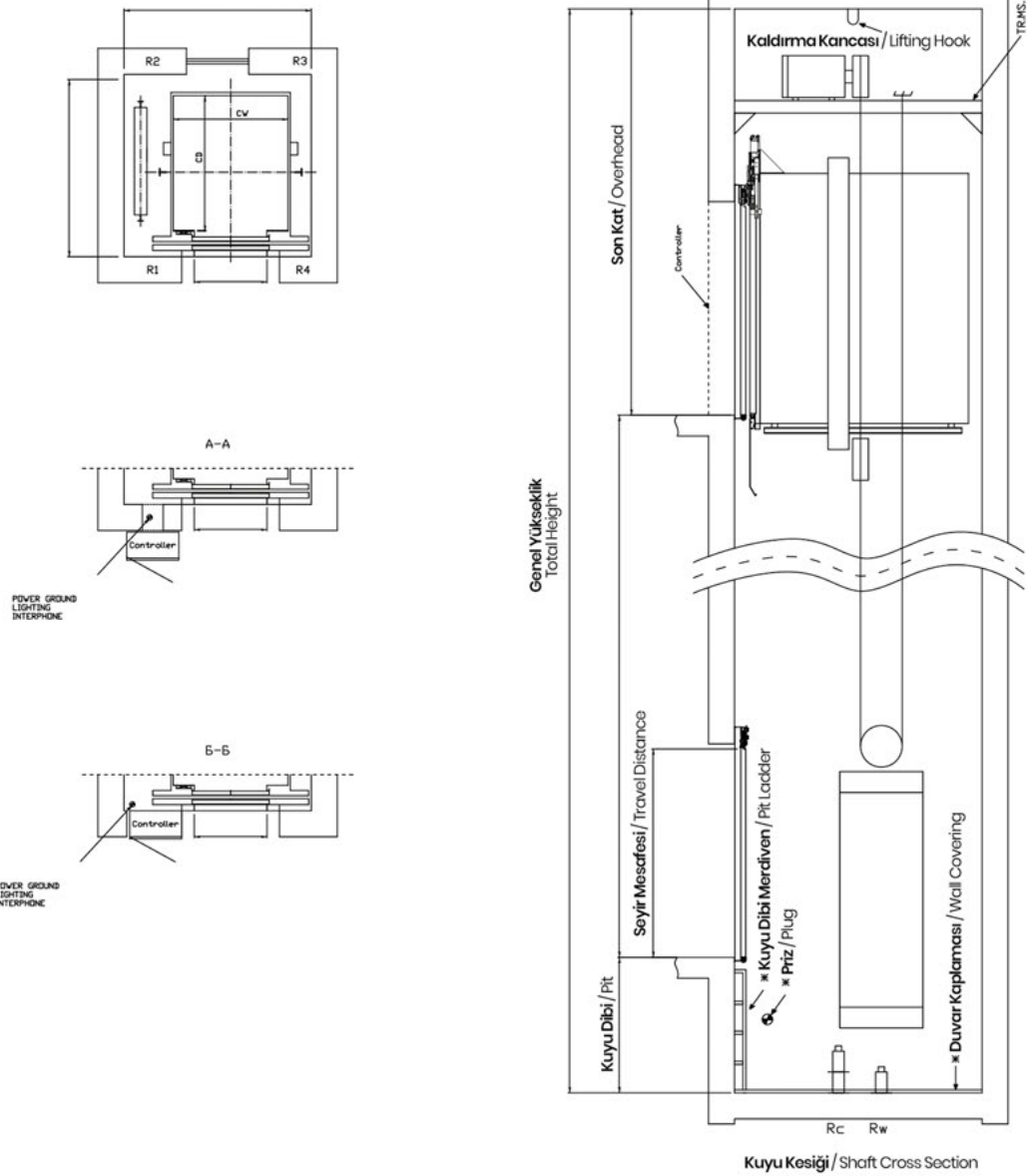
MAKİNE DAİRESİZ ASANSÖR
MACHINE ROOMLESS ELEVATORS

Hız Speed (M/C)	Kapasite Capacity		Kapi Door		Kabin Cabin		Kuyu / Shaft Tekli / Single		Süspansiyona Uygulanan Basınç Pressure On Suspension (KG)				Kuyu Dibi Basınç Pit Pressure (KG)		
	Kipi Rasyon	KG	Tip Type	Genişlik Width	CW	CD	HW	HD	R1	R2	R3	R4	Rc	Rw	
0.40 ~ 2.0	6	450	2P-CO	700	1100	1100	1850	1750	2200	4000	1500	400	4500	3250	
	7	525	2P-CO	800	1100	1300	1900	1800	2200	4000	1500	400	4500	3250	
	8	630	2P-CO	800	1100	1400	1900	1900	2200	4300	1600	600	4800	3500	
	9	680	2P-CO	800	1300	1300	2100	1850	2200	4300	1600	600	4800	3500	
	10	750	2P-CO	800	1300	1400	2100	1900	2300	4500	1700	600	5000	3700	
	11	900	2P-CO	900	1500	1400	2300	1900	2600	5100	1900	700	5700	4300	
	13	1000	2P-CO	1000	1600	1400	2400	1900	2600	5200	1900	700	6700	4800	
			2P-2S	1000	1100	2100	1900	2550							
	15	1150	2P-CO	1000	1800	1450	2550	1900	2900	5850	2150	850	8000	5800	
	17	1275	2P-CO	1100	2000	1400	2950	2200	3500	6800	2500	1100	9400	6800	
	21	1600	2P-CO	1200	2100	1600	3050	2300	4700	7200	3000	1200	11000	7500	
	26	2000	2P-CO	1200	2350	1650	3300	2450	6200	7600	3500	1400	17500	10500	

Kapasite (KG) Capacity	Hız Speed	Son Kat Overhead	Kuyu Dibi Pit	Not Note
400 - 1150	1.0	3600	1500/1200	
	1.6	3900	1600	
	2.0	4000	1700	
1200 - 2000	0.40	3900	1600	
	0.63	4000	1700	



Revizyon Takoz Kutusu
Revision Wedge Box



UPS
UPS



Konsol
Bracket



Ray
Guide Rail



Kapı Kılıç
Door Skate



Makine Takozu
Motor Wedge



Kablo
Cable



Halat Şişesi
Rope Hock



Yağdanlık
Oil Cup



Kabin Balkon
Cabin Balcony



Seperatör Sac
Seperator Sheet



Flexible Kablo
Flexible Cable



Ağırlık Şase Paten
Guide Shoes Counterweight



Kauçuk Tampon
Rubber Buffer



Hidrolik Tampon
Hydraulic Buffer



Halat
Rope



Makaralı Paten
Roller Skating



Karşı Ağırlık
Counter Weight



Fotosel
Photocell



Bistabil Monostabil Şalter
Bistabiling Monostabilis Switch



Paten Ağızlığı
Skating Mouthpiece



Regulör
Speed Regulator



Kasnak
Pulley



Süspansiyon Paten
Suspension Shoes

Açık Tip Engelli Platformu
Open Type Disabled Platform



Ev Asansörü
Home Elevator



Merdiven Engelli Platformu
Disabled Stair Platform
(Wheel Chairlift)



Kapalı Tip Engelli Platformu
Closed Type Disabled Platform



ÖZELLİKLER

- 1.Sınıf al dkb 1.5mm sac ve paslanmaz malzemeden imal edilmiştir.
- Ses ve titreşime karşı desteklenmiştir.
- Elektrik kesintisinde 12 vds voltaj akü takviyesiyle kapı otomatik olarak açılabilir ve fiziksel bir engelde otomatik geri açılabilme özelliğine de sahiptir.
- Programlanabilir micro işlemcili kart kullanılmaktadır.
- Uluslararası standartlara uygun imal edilmektedir.

PROPERTIES

- The being produced with first class al dkb 1.5mm stainless metal sheet material.
- Supported against sound and vibration.
- Door could be open automatically in any power cut with the support of 12 vds voltage battery and has a automatically back opening property in any physical fence.
- Programmable micro-processor card is used
- Being produced according to international standards.



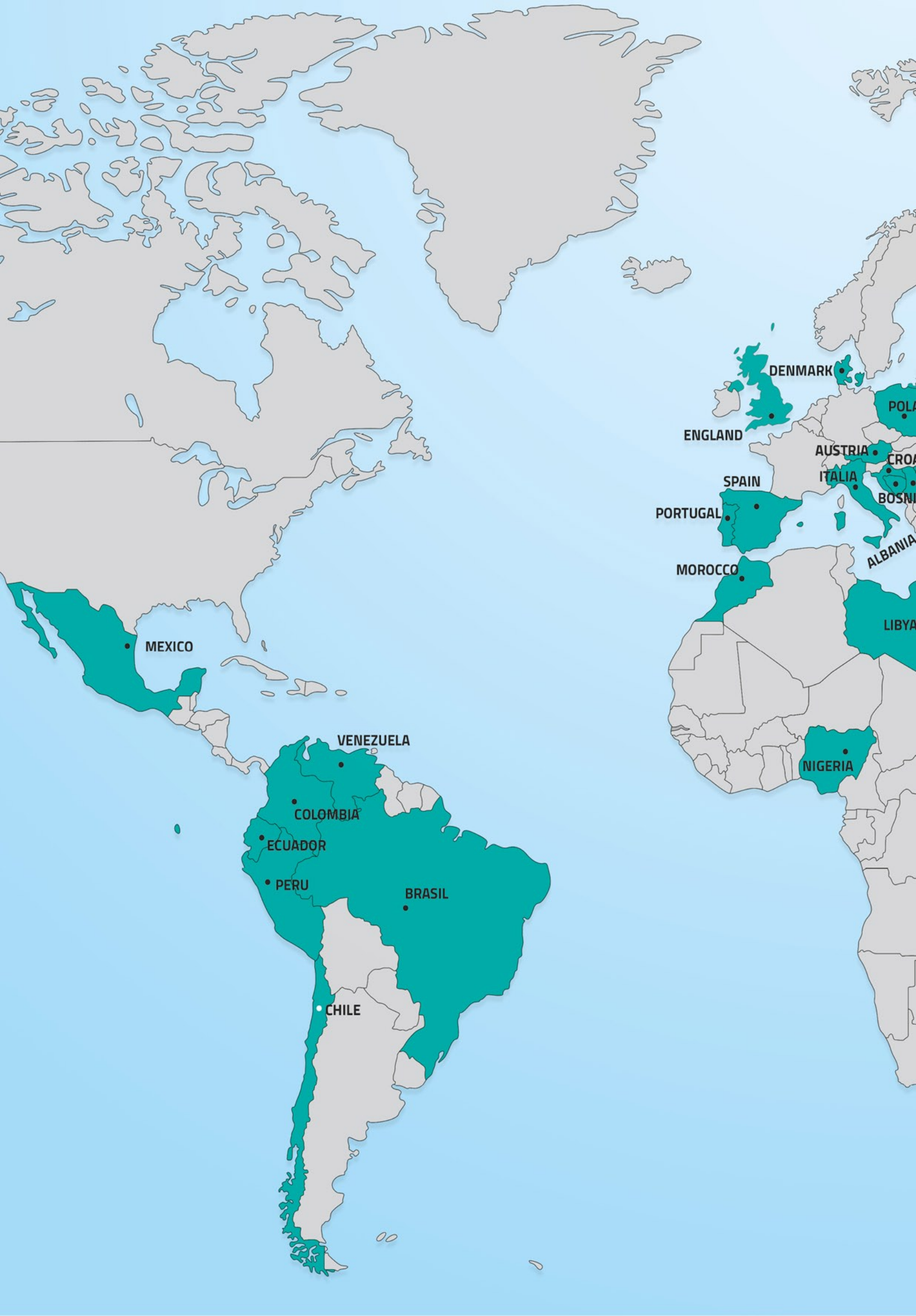

MEXICO

VENEZUELA

COLOMBIA

ECUADOR

PERU

BRASIL

CHILE

DENMARK

ENGLAND

PORTUGAL

MOROCCO

SPAIN

AUSTRIA

ITALIA

ALBANIA

LIBYA

POLA

CROA

BOSNI

NIGERIA

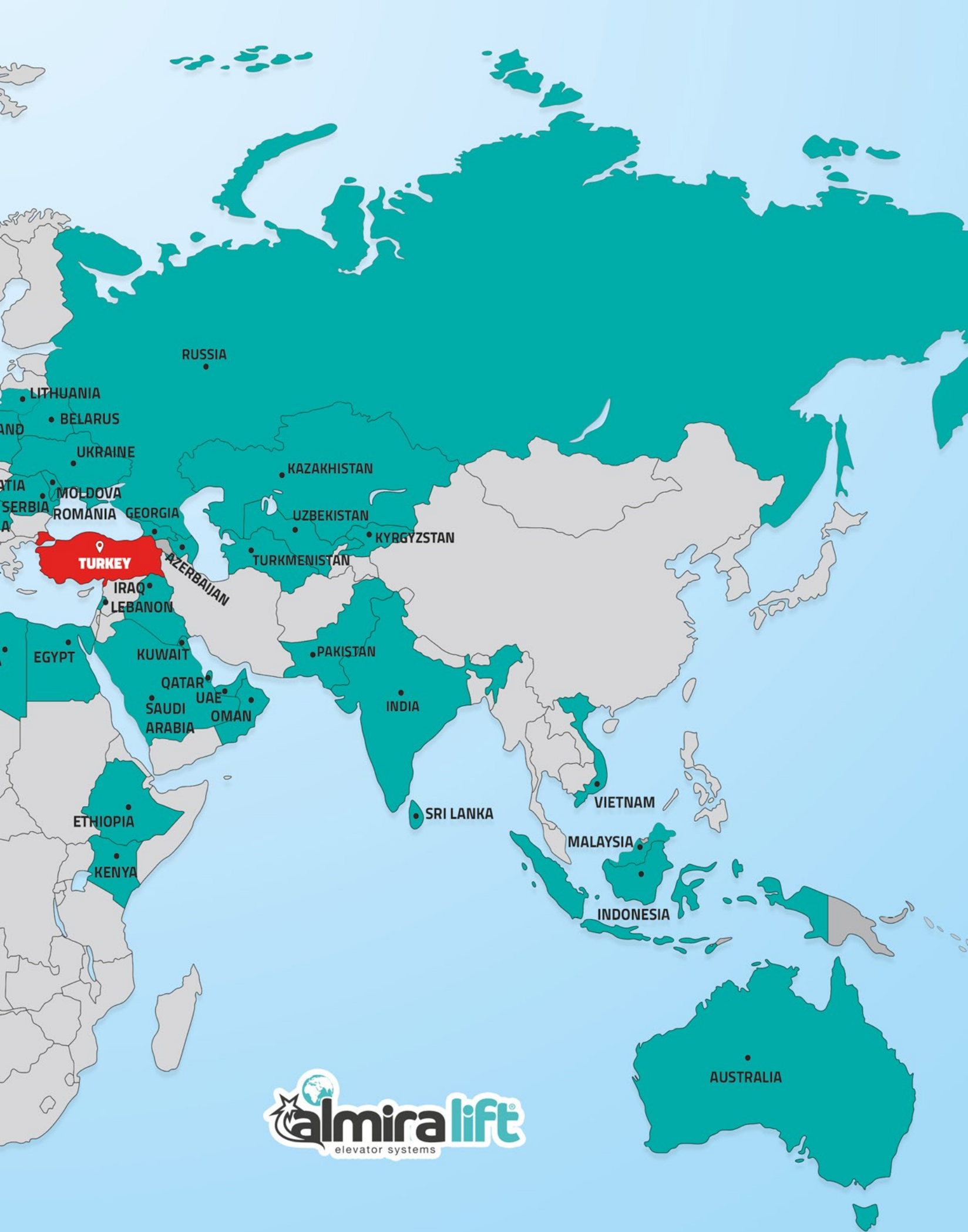

RUSSIA

LITHUANIA

BELARUS

UKRAINE

KAZAKHISTAN

MOLDOVA

ROMANIA

GEORGIA

UZBEKISTAN

KYRGYZSTAN

TURKEY

TURKMENISTAN

IRAQ

LEBANON

AZERBAIJAN

PAKISTAN

INDIA

EGYPT

KUWAIT

QATAR

SAUDI ARABIA

UAE

OMAN

ETHIOPIA

KENYA

SRI LANKA

VIETNAM

MALAYSIA

INDONESIA

AUSTRALIA





ALMİRALİFT ASANSÖR MAK. İMALAT SAN. İÇ ve DIŞ TIC. LTD. ŞTİ.

A F. Çakmak Mh. 10728 Sk No:16 KONYA - TÜRKİYE

T +90 332 503 40 84 **F** +90 332 503 40 84

M info@almiralift.com.tr

W www.almiralift.com.tr

